

SUSPENSION SYSTEMS

making everyday smoother

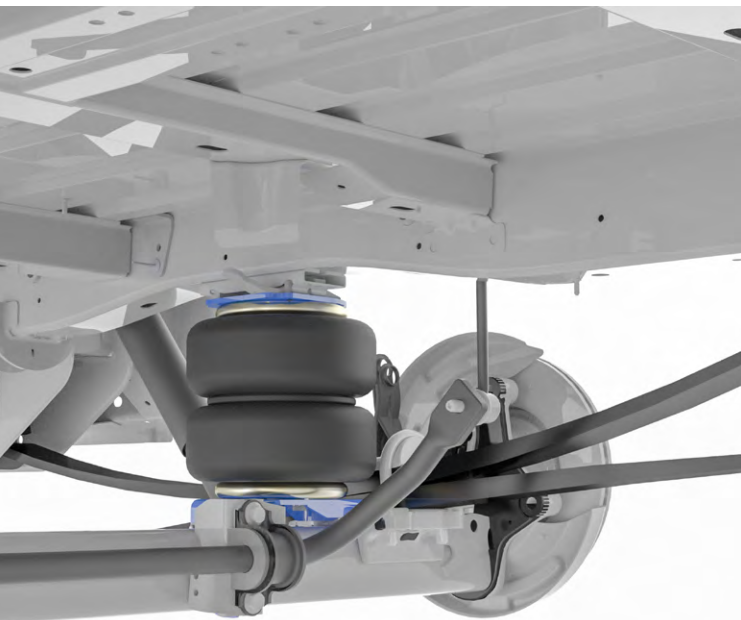

airsuspension



DISCOVER THE POSSIBILITIES OF VB-AIRSUSPENSION

BETTER SAFETY AND COMFORT ON THE ROAD.

VB-SemiAir

Semi air suspension

OUR VB-SEMAIR SYSTEMS INCLUDE THE FOLLOWING BENEFITS:
IMPROVED COMFORT – GREATER STABILITY – OPTIMUM DRIVEABILITY.



CREATE MORE SPRING TRAVEL WITH SEMI AIR SUSPENSION.

VB-SemiAir: semi air suspension

Semi air suspension enables the suspension to be adjusted within specific limits. On a vehicle with leaf springs, an air spring is fitted between the chassis and the rear axle. This air spring supports the existing leaf spring.

WORRY LESS ABOUT YOUR LOAD.

VB-SemiAir is supplied as a two-chamber system. This means that the air springs are not connected to each other. The use of a two-chamber system allows left and right to be adjusted separately, enabling the vehicle to be levelled to a certain extent even when it is loaded unevenly.

	Increasing the ride height	Minimising sagging	Reducing vehicle roll	Improving suspension comfort
VB-SEMAIR Semi air suspension	++	++	+	++
	Improving driving characteristics	Automatic adjustment		
	+			



VB-SEMIAIR IS OFTEN FITTED TO MEET THE FOLLOWING REQUIREMENTS:

- INCREASED RIDE HEIGHT** ■
- MINIMISED SAGGING** ■
- REDUCED VEHICLE ROLL** ■
- IMPROVED SUSPENSION COMFORT** ■
- IMPROVED DRIVING CHARACTERISTICS** ■



DISCOVER THE VARIOUS SEMI AIR SUSPENSION SYSTEMS.

- VB-SemiAir basic system
- VB-SemiAir comfort system
- VB-LevelAir (VB-SemiAir basic system including automatic level control)

BENEFITS OF VB-SEMIAIR:

- HIGHER RIDE HEIGHT AND INCREASED SPRING TRAVEL
- IMPROVED STABILITY
- REDUCED OFF-CENTRE LEVEL
- VARIABLE SPRING FORCE
- GOOD VALUE FOR MONEY
- 'PLUG-AND-PLAY' SYSTEM ALLOWS FOR QUICK INSTALLATION
- THE BODY, EQUIPMENT AND LOAD REMAIN PROTECTED AGAINST VIBRATION/IMPACT
- HEAVY LOADS ARE NO LONGER NOTICEABLE FROM THE OUTSIDE
- LESS STRAIN ON THE SHOCK ABSORBERS

SETTING THE SUSPENSION WITHIN CERTAIN LIMITS.

VB-SemiAir basic system

The VB-SemiAir basic system enables the spring force to be adjusted within specific limits. On a vehicle with leaf springs, air springs are fitted between the chassis and the rear axle. This air springs support the existing leaf spring. The VB-SemiAir basic system is therefore a good option for vehicles that always carry a heavy load and that occasionally carry variable loads (the pressure can stay more or less the same). You will need to pressurise the VB-SemiAir basic system yourself using an external air supply, e.g. a tyre inflater.

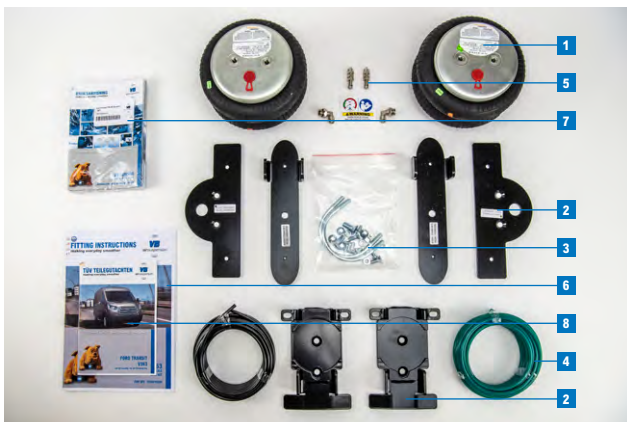
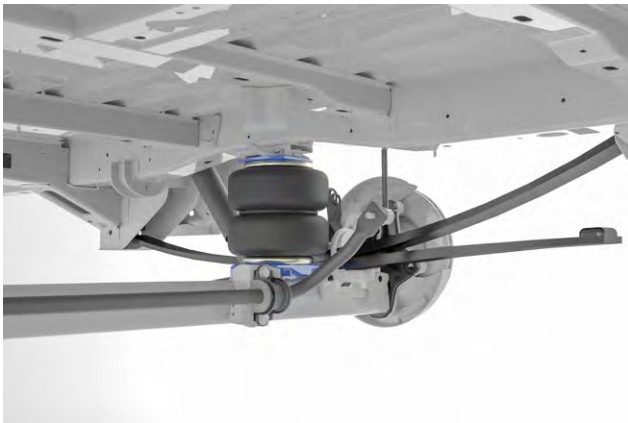

THE SET OF THE VB-SEMIAIR BASIC SYSTEM CONSISTS OF:

1	Air springs	+
2	Brackets	+
3	Fasteners	+
4	Air tubes	+
5	Inflation valves	+
6	Fitting instructions	+
7	User manual	+
8	Approval documentation	+

SIMPLE MANUAL OPERATION OF THE SEMI AIR SUSPENSION.

VB-SemiAir comfort system

The VB-SemiAir comfort system enables the spring force to be adjusted (manually) within specific limits. On a vehicle with leaf springs, an air spring is fitted between the chassis and the rear axle. This air spring supports the existing leaf spring.

The VB-SemiAir comfort system is therefore a good option for vehicles that frequently carry a heavy load and that regularly carry variable loads.

The VB-SemiAir comfort system consists of a VB-SemiAir basic system, including control panel with two pressure gauges, two high/low switches and a powerful heavy-duty compressor. The high/low switches enable you to change ride height of your vehicle easily. The pressure gauges give an accurate reading of the pressure (in bar) in the air springs, allowing you to easily inflate the air springs.



Control panel
LCV



Control panel
Motorhomes

THE SET OF THE VB-SEMAIR COMFORT SYSTEM CONSISTS OF:

Set photo: see pages 10 and 11

1	Air springs	+
2	Brackets	+
3	Fasteners	+
4	Air tubes	+
5	Control panel	+
6	High/low switches	+
7	Pressure gauges	+
8	Compressor	+
9	Fitting instructions	+
10	User manual	+
+	Approval documentation	+



9 10 5 6 7

8 3 2 1 4

In addition to the products from the 'semi air suspension' product group, we also offer a wide range of other products. Our products fall into one of four product groups. These product groups contain a variety of systems for many different makes and models, meaning that there is always a suitable solution for you.



FULL AIR SUSPENSION



SEMI AIR SUSPENSION



HELPER AND REINFORCED SPRINGS

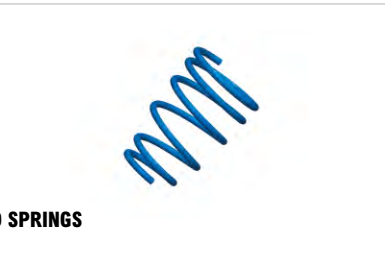

SPECIAL COMPONENTS



DISCOVER OUR PRODUCT GROUPS.

Full air suspension

Full air suspension is an automatic, adjustable solution to a suspension problem where the existing leaf or coil spring suspension is replaced by a full air suspension system. Depending on the make and model of vehicle, full air suspension is available for both the front and rear axle.

Helper and reinforced springs

Helper and reinforced springs are suspension systems that support or reinforce the existing suspension system in order to correct a suspension problem. The helper and reinforced springs are either fitted to the existing suspension or replace the original spring suspension. The two systems are available for both the front and rear axle.

Special components

Reinforced stabiliser

A reinforced stabiliser is a solid rod of the same material as the springs. This roll stabiliser supports the existing suspension. The roll stabiliser is added to the existing suspension system and is available for both the front and rear axle.

Reinforced shock absorbers

Reinforced shock absorbers have their own suspension characteristics. They replace the original shock absorbers, thus becoming part of the existing suspension. Reinforced shock absorbers are available for both the front and rear axle.

VB-FSD technology

VB-FSD shock absorbers use VB-FSD technology (FSD stands for 'Frequency Selective Damping'). The VB-FSD shock absorbers have double damping characteristics. They replace the original shock absorbers and thus become part of the existing suspension. Shock absorbers with VB-FSD technology are available for both the front and rear axle.

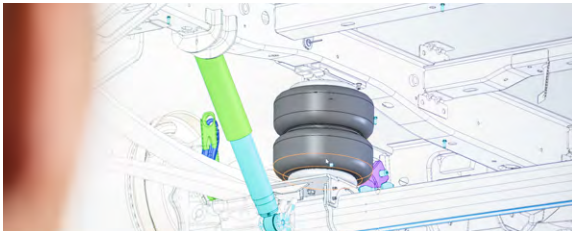

WE MAKE EVERY JOURNEY
A GOOD ONE.



VB-AIRSUSPENSION IS ACTIVE WORLDWIDE.

As a leading company experiencing rapid growth, we want all our customers across the globe to benefit from our premium suspension applications. These suspension applications provide improved comfort, better driving characteristics and improved safety, in turn making every day smoother.

MAKING EVERYDAY SMOOTHER.

According to this motto, we aim to provide our customers with the best possible service – and we've been very successful so far! After all, our highly motivated team has been developing and building suspension applications and various air suspension systems for light commercial vehicles, ambulances, car transporters, motorhomes, 4x4 vehicles and off-road vehicles for more than 28 years. Our product portfolio ranges from reinforced springs to full air suspension solutions with active shock absorbers for front and rear axles. We are especially proud of our official recognition from big names such as Mercedes-Benz, Volkswagen, Ford, Renault, PSA and AL-KO – the highest recognition that an accessory specialist can receive from a vehicle manufacturer. TÜV approvals and 'Letters Of No Objection' (LONO) from various vehicle manufacturers mean that our products are also available for other vehicles.

- MORE THAN 28 YEARS OF EXPERIENCE
- 150 EMPLOYEES
- 8 SUBSIDIARIES WORLDWIDE
- REPRESENTED BY PARTNERS IN 40 COUNTRIES
- DELIVERY TO MORE THAN 60 COUNTRIES
- MORE THAN 225 ACCREDITED INSTALLATION PARTNERS
- MORE THAN 825 TRAINED SPECIALISTS
- MORE THAN 200,000 AIR SUSPENSION SYSTEMS SOLD

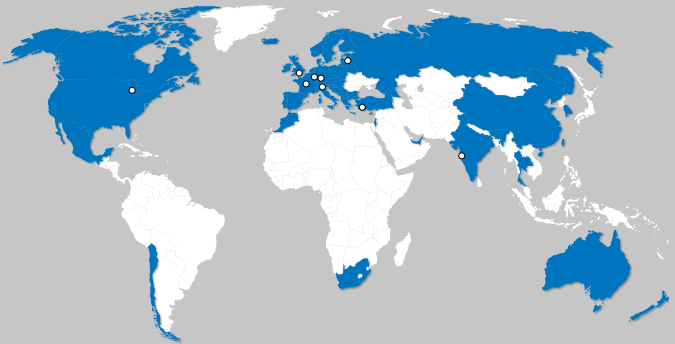

DISCOVER OUR PRODUCTS.

Our products find their way to satisfied users through an extensive network of international partners and dealers. Our partners and dealers are authorised specialists that have received extensive training in the installation of our products and in the provision of a high-quality service and appropriate advice.

To find your nearest partner or dealer,
visit www.vbairsuspension.com.