

• **VB-FullAir-2C**
Technical specifications

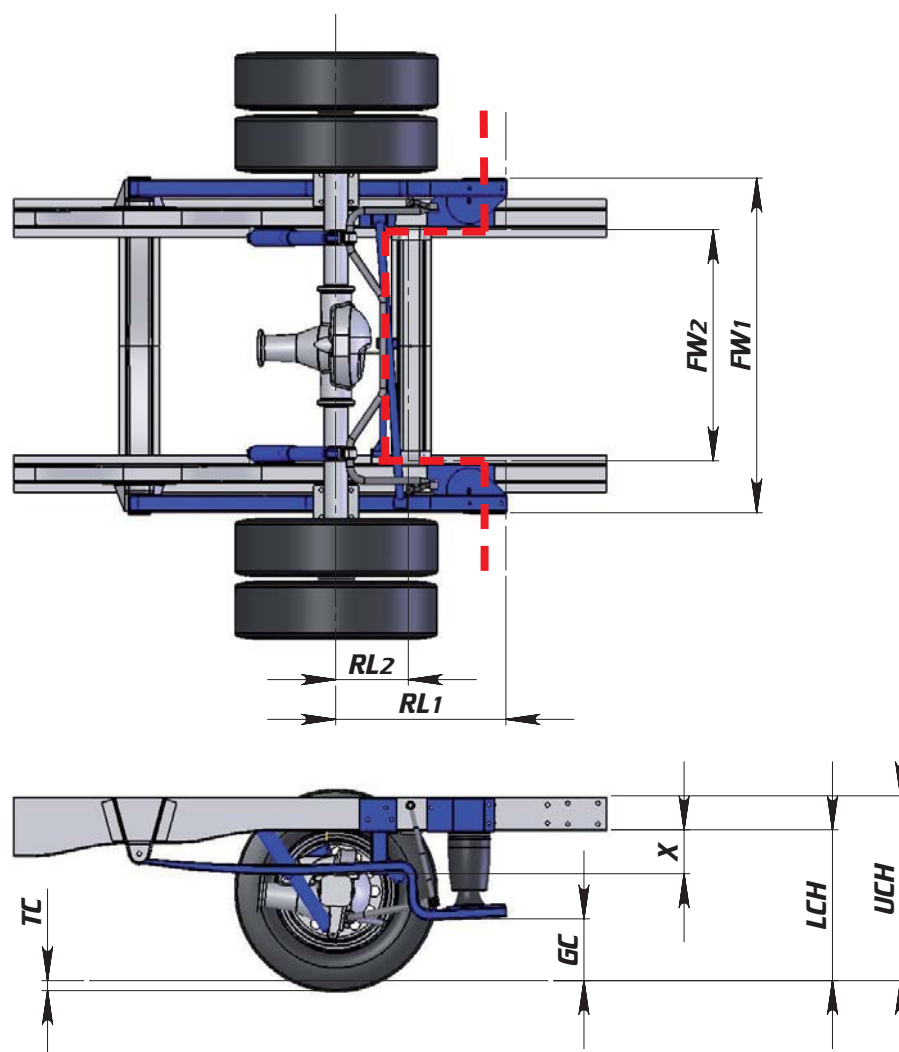

Ford Transit 350 - 460 Chassis Cab



Description*	Min. height	Ride-height	Max. height
Lower chassis height (LCH)	465	525	550
Upper chassis height (UCH)	590	650	675
Ground clearance (GC)	245	205	185
X-value (X)	90	160	185
Rear length (RL1 / RL2)	600 / 250		
Frame width (FW1 / FW2)	1180 / 830		

* All the measurements are in mm, measured above the centre-line of the rear axle on a standard chassis, with tyre size 195/75R16 and a rear axle load of 1650kg. Therefore a tyre compression (TS) of 20mm is included.

Ford Transit 350 - 460 Chassis Cab

Technical specifications

Air-suspension system

Suspension system contains mainsprings (trailing arms) with air-springs, shock absorbers and a stabiliser bar. The system has a dual-air-circuit with twin height sensors.

The electronics of the air suspension is tested according to EMC (European directives for electronics) directive 72/245/EEC last amended, 2006/28/EC.

The air-suspension can be controlled by the supplied remote control. There are different options for this: VB-SRC (Standard Remote Control) or a simple control unit. It's even possible to control the system through the electrical system or CAN-bus system of the body builder. For more information, contact VB-Airsuspension.

Weights

The weight change of the vehicle after switching to air-suspension is: +46kg

Raise- and lowertimes

The raise and lower times depend on the load of the vehicle. The measured values are achieved with a rear axle load of 1650kg.

Raise time lowest position > ride height:	22 sec
Raise time ride height > highest position:	45 sec
Lower time highest position > ride height:	15 sec
Lower time ride height > lowest position:	9 sec

Compressor

Contains an air dryer, thermal circuit breaker and a pressure protection valve.

Operating voltage: 12V
Nominal current: 26A
Starting current: $\leq 120A$ over $t \leq 100ms$
Degree of protection : IP68
Maximum pressure: 10-13 bar

Air-spring

VB-TS (Tapered Sleeve) with double polyamide cord ply and extra low resistance and hysteresis. This air-spring is specially developed for use with light commercial vehicles.

Shock absorber

Adjustable, double-acting shock absorber.

Options

- Emergency valve kit 2C
- Rear-door switch kit
- Extra-time module
- VB-AOWS (Axle Overloading Warning System)

Notes

By fitting the air-suspension kit, the maximum GVW or the maximum axle load is not altered.

This air-suspension kit is also available with electronics for external air-supply. For more information, please contact VB-Airsuspension.

The measured weights are approximately determined.