

• **VB-FullAir-2C**
Technical specifications

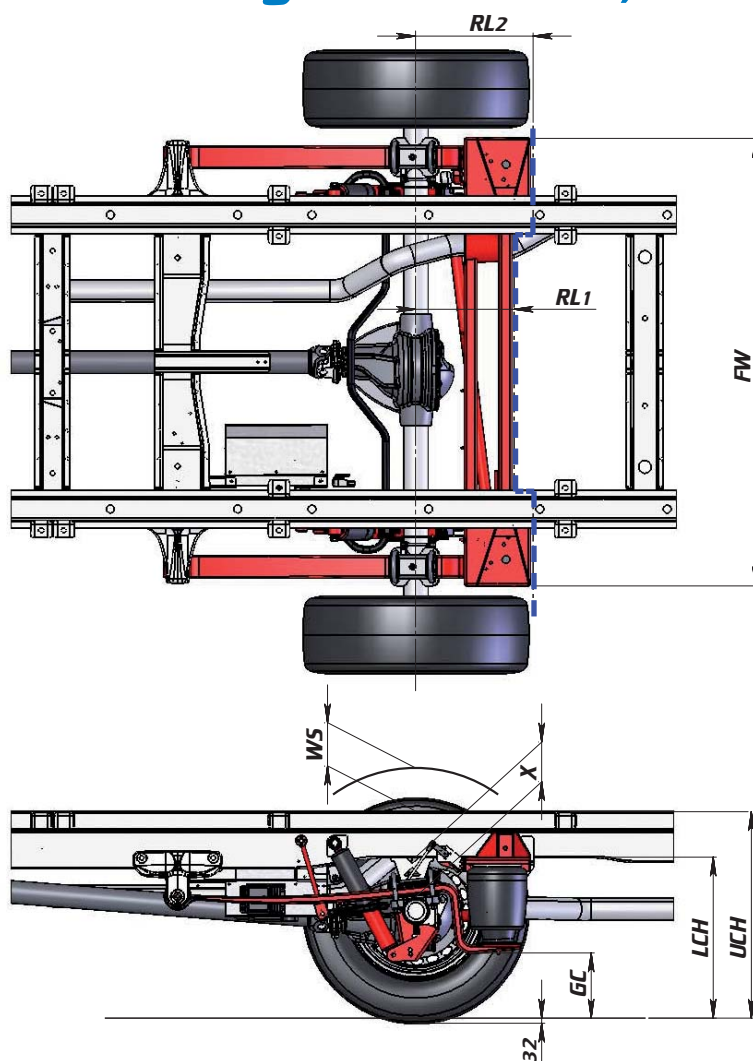

Volkswagen Crafter 3,5t



Description*	Min. height	Ride-height	Max. height	Min height	Ride-height	Max height
Rear axle type	Standard		Code 7WW or 7WX			
Lower chassis height (LCH)	435	495	515	450	510	530
Upper chassis height (UCH)	580	640	660	595	655	675
Ground clearance (GC)	190	175	170	210	190	180
X-value (X)	70	130	150	85	145	165
Rear length (RL1 / RL2)	310 / 370					
Frame width (FW)	1410					
Wheel space (WS)	190					

* All the measurements are in mm, measured above the centre-line of the rear axle on a standard chassis, with tyre size 235/65R16 and a rear axle load of 2250kg. Therefore a tyre compression of 32mm is included.

Volkswagen Crafter 3,5t

Technical specifications

Air-suspension system

Suspension system contains mainsprings (trailing arms) with air-springs, shock absorbers and a stabiliser bar. The system has a dual-air-circuit with twin height sensors.

The electronics of the air suspension is tested according to EMC (European directives for electronics) directive 72/245/EEC last amended, 2006/28/EC.

The air-suspension can be controlled by the supplied remote control. There are different options for this: VB-SRC (Standard Remote Control) or a simple control unit. It's even possible to control the system through the electrical system or CAN-bus system of the body builder. For more information, contact VB-Airsuspension.

Weights

The weight change of the vehicle after switching to air-suspension depends of the kind of leaf springs removed.

For leaf spring 2E0 511 131 Q: +30kg
For leaf spring 2E0 511 131 H: +30kg
For leaf spring 2E0 511 131 AD: +46kg

Raise- and lowertimes

The raise and lower times depend on the load of the vehicle. The measured values are achieved with a rear axle load of 2250kg.

Raise time lowest position > ride height:	21 sec
Raise time ride height > highest position:	40 sec
Lower time highest position > ride height:	11 sec
Lower time ride height > lowest position:	8 sec

Compressor

Contains an air dryer, thermal circuit breaker and a pressure protection valve.

Operating voltage: 12V
Nominal current: 26A
Starting current: ≤ 120A over t ≤ 100ms
Degree of protection : IP68
Maximum pressure: 10-13 bar

Air-spring

VB-TS (Tapered Sleeve) with double polyamide cord ply and extra low resistance and hysteresis. This air-spring is specially developed for use with light commercial vehicles.

Shock absorber

Adjustable, double-acting shock absorber.

Options

- Emergency valve kit 2C
- Rear-door switch kit
- Extra-time module
- VB-AOWS (Axle Overloading Warning System)

Notes

For the fitting of the air-suspension kit the factory option UF3 is required.

By vehicles with a wheelbase of 3250mm it isn't possible to mount a spare wheel. The next options must be ordered at the factory: 1BO / 1GO / 1G8. The spare wheel will not be mounted and the vehicle will be delivered with a emergency inflating kit for the wheels.

When, at this wheelbase, no stabiliser is mounted at the rear axle, please order the reaction arms VB-article no.: 1052350015.

The air-suspension system will not fit underneath a vehicle in combination with a factory modified exhaust (factory option OP7). Please make sure the vehicle will be ordered with exhaust OP6. If the vehicle is equipped with the exhaust OP7, which will go in front of the rear axle from left to right, it has to be replaced by a exhaust which will go straight to the rear of the vehicle. VB-article no.: 1052350021 (Kit includes mounting brackets).

The WS measure does not reckon with the fitment of snow chains.

By fitting the air-suspension kit, the maximum GVW or the maximum axle load is not altered.

This air-suspension kit is also available with electronics for external air-supply. For more information, please contact VB-Airsuspension.

The measured weights are approximately determined.