

• **VB-FullAir**

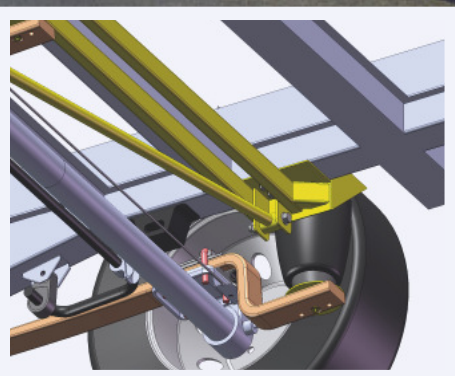

The Opel Movano x-70



with VB-FullAir rear axle air suspension

Opel Movano also available with VB-FullAir rear axle air suspension

The Opel Movano is available with rear axle air suspension. The Movano is extremely suited for the use of air suspension systems and our VB-FullAir-2C is available for new and used vehicles. This newly developed rear axle air suspension, from VB-Airsuspension, is available as an after-market option through the Opel network, or direct from VB.

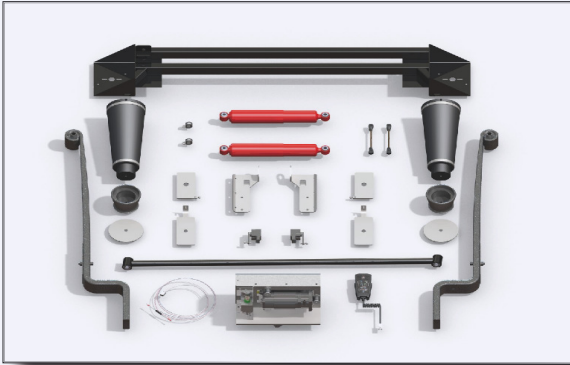

VB-FullAir 2C system

The VB-FullAir, a full-air rear-axle air-suspension, has an electronic system named VB-ASCU (VB-Air Suspension Control Unit), which automatically monitors and adjusts the ride-height of the vehicle. This constant monitoring and adjusting (independent of the load, in the longitudinal and lateral direction) will automatically contribute to a safe vehicle behaviour and improved comfort. The vehicle may not be overloaded.

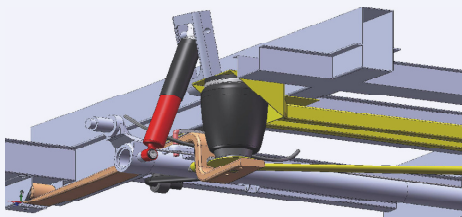

Software

The electronic part of the rear axle air suspension is compatible with the vehicle's main electrical system. Various software variants create the possibility to adapt the VB-FullAir 2C air-suspension to the specific use of the vehicle.



Changing height

The vehicle level can be changed manually with the standard hand-held when the vehicle stands still; therefore lowering of the chassis / load platform is one of the systems standard possibilities.



Advantages VB-FullAir 2C::

- Improved suspension comfort
- Constant ride height
- Improved road handling and stability
- Increased protection of vulnerable / sensitive goods
- Less impact for passengers
- Kneeling facility
- Less wear of tyres / brakes
- Environmentally friendlier, less CO2 emission

Market circumstances

The Opel Movano X-70 will be used for a wide range of individual needs and market circumstances where air suspension is essential. For example: passenger transport, disabled persons transport, rescue vehicles, motorhomes, car transporters and for the transport of shock-sensitive products. For these and more usages, and individual needs, our VB-FullAir-2C is the right solution.

Supply and service

Air-suspended Movano's can be supplied and serviced by VB-Airsuspension dealers and the Opel dealer organisation.

VB-Airsuspension data:

| | Chassis cab * | Van * |
|-------------------------------------|---------------|------------|
| Standard driving height (unloaded) | 662-667 mm | 538-545 mm |
| Standard driving height (max. load) | 610-620 mm | 485-490 mm |
| Driving height with VB-FullAir-2C | 570 mm | 475 mm |
| Highest position | +30 mm | +40 mm |
| Lowest position | - 75 mm | - 90 mm |

*Chassis height chassis cab. measured at the upper crossbeam, above the rear axle

*Chassis height van measured on the loading floor at the rear of the car.

For more information: info@vbairsuspension.com

