

• *VB-FullAir*



The Mercedes-Benz Sprinter 3,5 T 4X4



with VB-FullAir rear axle air suspension

Mercedes-Benz Sprinter 3,5 T 4x4 also available with VB-FullAir rear axle air suspension

The Mercedes-Benz Sprinter 3,5 T 4x4 is available with rear axle air suspension. The Sprinter is extremely suited for the use of air suspension systems. Our VB-FullAir-2C is available for new and used cars. The newly developed rear axle air suspension, from the Dutch company VB-Airsuspension, is available as an after-market option through the Mercedes-Benz network.

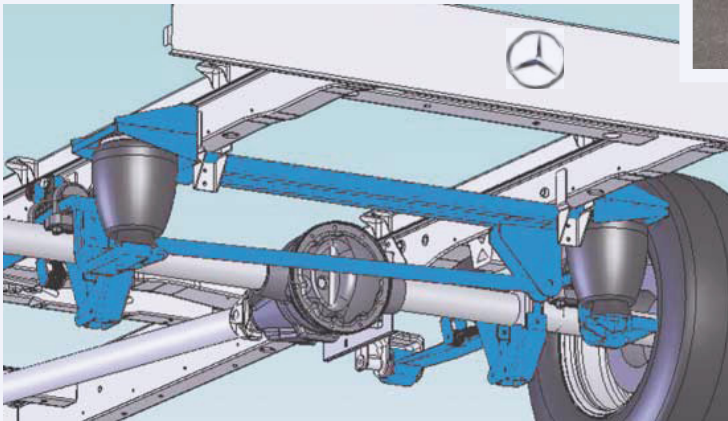

The Mercedes-Benz Sprinter will be used for a wide range of individual needs and market circumstances where air suspension is essential. For example: passenger transport, disabled persons transport, rescue vehicles, motorhomes, car transporters and for the transport of shock-sensitive products. For these and more usages, and individual needs, our VB-FullAir-2C is the right the solution.

VB-Airsuspension data:

	Normal axle	Heavy axle
Standard driving height (unloaded)	740 mm	755 mm
Standard driving height (max. load)	700 mm	715 mm
Driving height with VB-FullAir-2C	715 mm	730 mm
Highest position	+20 mm	+20 mm
Lowest position	- 60 mm	- 60 mm
Chassis height at the rear axle.		

Attention!! When ordering the vehicle, please always order factory option **EK1!!**

The electronic part of the rear axle air suspension is compatible with the vehicle's main electrical system. Various software variants create the possibility to adapt the VB-FullAir 2C air-suspension to the specific use of the vehicle.

Air-suspended Sprinters 4x4 will be supplied and serviced by the Mercedes-Benz dealer organisation.



For more information: info@vbairsuspension.com

