

• *VB-FullAir*



The Mercedes-Benz Sprinter 3,5 T '06>



with VB-FullAir rear axle air suspension

Mercedes-Benz Sprinter 3,5 T also available with VB-FullAir rear axle air suspension

The Mercedes-Benz Sprinter is available with rear axle air suspension. The Sprinter is extremely suited for the use of air suspension systems and our VB-FullAir-2C is available for new and used vehicles. This newly developed rear axle air suspension, from VB-Airsuspension, is available as an after-market option through the VB-Air-suspension dealers and Mercedes-Benz network.

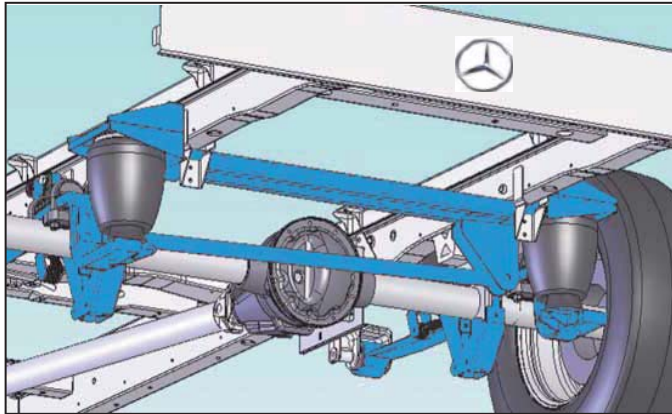

Market circumstances

The Mercedes-Benz Sprinter will be used for a wide range of individual needs and market circumstances where air suspension is essential.

For example: passenger transport, disabled persons transport, rescue vehicles, motorhomes, car transporters and for the transport of shock-sensitive products. For these and more usages, and individual needs, our VB-FullAir-2C is the right solution.

VB-FullAir-2C system

The VB-FullAir, a full-air rear-axle air-suspension, has an electronic system named VB-ASCU (VB-Air Suspension Control Unit), which automatically monitors and adjusts the height level of the vehicle.

This constant monitoring and adjusting (independent of the load, in the longitudinal and lateral direction and relatively independent of centre gravity height) will automatically contribute to a safe vehicle behaviour and a better comfort. The vehicle may not be overloaded.

Changing height

The vehicle level can be changed manually with the standard handheld when the vehicle stands still; therefore lowering of the chassis/load platform is one of the systems standard possibilities.



Software

The electronic part of the rear axle air suspension is compatible with the vehicle's main electrical system. Various software variants create the possibility to adapt the VB-FullAir-2C air-suspension to the specific use of the vehicle.



Advantages VB-FullAir 2C:

- Improved suspension comfort
- Constant ride height
- Improved road handling and stability
- Increased protection of vulnerable / sensitive goods
- Less impact for passengers
- Kneeling facility
- Less wear of tyres / brakes
- Environmentally friendlier, less CO2 emission

Supply and service

The air-suspension of the Mercedes-Benz Sprinter can be supplied and serviced by VB-Airsuspension dealers and through the Mercedes-Benz dealer organisation.

Attention!! When ordering the vehicle, please always order factory option **EK1!!**

Technical specifications:	Normal axle	Heavy axle*
Standard ride-height (unloaded)	730 mm	730 mm
Standard ride-height (maximum load)	600 mm	600 mm
Ride-height with VB-FullAir-2C	640 mm	655 mm
Highest position (0-5km/h)	+20 mm	+20 mm
Lowest position (0-5km/h)	-60 mm	-60 mm

* Heavy axle: MB code AR1 of AR2

* All the measurements are in mm, measured above the centre-line of the rear axle on a standard chassis, with tyre size 235/65R16 and a rear axle load of 2250kg. Therefore a tyre compression of 32mm is included.

For more information: info@vbairsuspension.com



© 01-2010