

• **VB-FullAir-2C**
Technical specifications

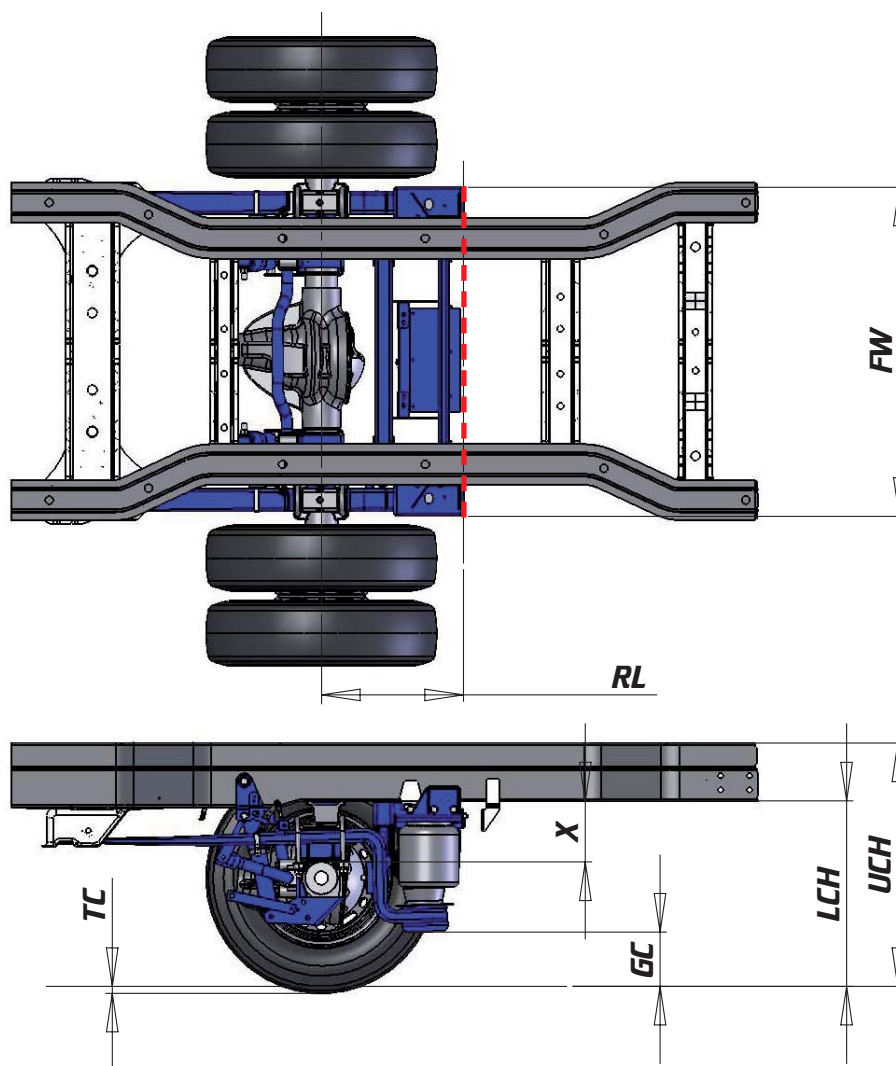

Mercedes-Benz Sprinter 5,0t 4X4



Description*	Min. height	Ride-height	Max. height
Lower chassis height (LCH)	495	540	565
Upper chassis height (UCH)	675	720	745
Ground clearance (GC)	190	175	170
X-value (X)	125	175	200
Rear length (RL)	440		
Frame width (FW)	770		

* All the measurements are in mm, measured above the centre-line of the rear axle on a standard chassis, with tyre size 205/75R16 and a rear axle load of 3070kg. Therefore a tyre compression of 20mm is included.

Mercedes-Benz Sprinter 5,0t 4X4

Technical specifications

Air-suspension system

Suspension system contains mainsprings (trailing arms) with air-springs, shock absorbers and a stabiliser bar. The system has a dual-air-circuit with twin height sensors.

The electronics of the air suspension is tested according to EMC (European directives for electronics) directive 72/245/EEC last amended, 2006/28/EC.

The air-suspension can be controlled by the supplied remote control. There are different options for this: VB-SRC (Standard Remote Control) or a simple control unit. It's even possible to control the system through the electrical system or CAN-bus system of the body builder. For more information, contact VB-Airsuspension.

Weights

The weight change of the vehicle after switching to air-suspension depends of the kind of leaf springs removed.

For leaf spring A906 320 0206: +42kg

Raise- and lowertimes

The raise and lower times depends on the load of the vehicle. The measured values are measured by a rear axle load of 3070kg.

Raise time lowest position > ride height: 45,5 sec

Raise time ride height > highest position: 20 sec

Lower time highest position > ride height: 9,5 sec

Lower time ride height > lowest position: 15,5 sec

Compressor

Contains an air dryer, thermal circuit breaker and a pressure protection valve.

Operating voltage: 12V

Nominal current: 26A

Starting current: $\leq 120A$ over $t \leq 100ms$

Degree of protection : IP68

Maximum pressure: 10-13 bar

Air-spring

VB-TS (Tapered Sleeve) with double polyamide cord ply and extra low resistance and hysteresis. This air-spring is specially developed for use with light commercial vehicles.

Shock absorber

Adjustable, double-acting shock absorber.

Options

- Emergency valve kit 2C
- Rear-door switch kit
- Extra-time module
- VB-AOWS (Axle Overloading Warning System)

Notes

For the fitting of the air-suspension kit, the factory options EK1 and C43 are required.

When the vehicle doesn't have the option C43 (heavy stabiliser), there has to be an extra stabiliser bracket kit ordered by VB-Airsuspension (VB-article no.: 1052350021).

If the vehicle is equipped with Xenon headlights (factory option LG1), the control of it has to be modified. Please order the Xenon modification kit VB-article no.: 1052350009).

For vehicles with a wheelbase of 3665mm, the spare wheel bracket has to be modified. The original bracket on the chassis has to be removed and the spare wheel bracket is refitted to the upper crossbeam of the air-suspension. Another option is to order the following factory options: R92 / RR7 / R87.

The WS measure does not reckon with the fitment of snow chains.

By fitting the air-suspension kit, the maximum GVW or the maximum axle load is not altered.

This air-suspension kit is also available with electronics for external air-supply or with an increased driving height. For more information, please contact VB-Airsuspension.

The measured weights are approximately determined.