

• **VB-FullAir-2C**
Technical specifications

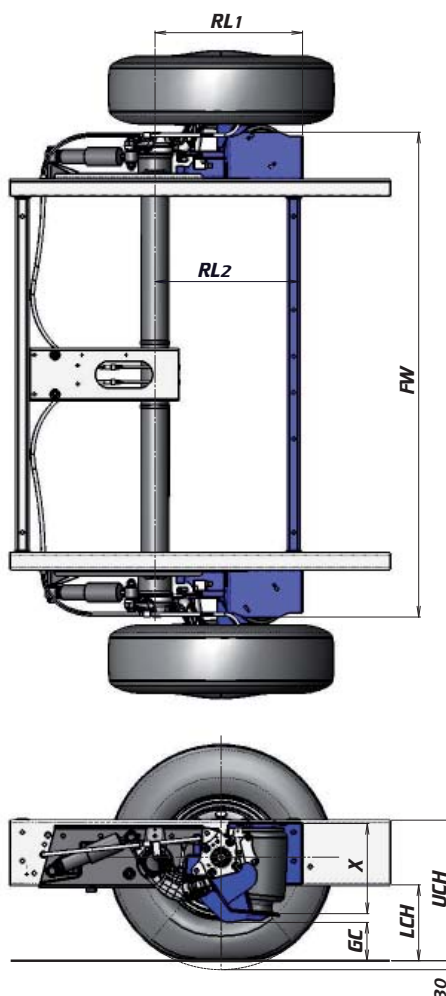

Fiat Ducato X250 with ALKO chassis



Description*	Min. height	Ride-height	Max. height
Lower chassis height (LCH)	166	269	298
Upper chassis height (UCH)	381	484	513
Ground clearance (GC)	152	127	111
X-value (X)	123	300	380
Rear length (RL1 / RL2)	490 / 480		
Frame width (FW)	1611		

* All the measurements are in mm, measured above the centre-line of the rear axle on a standard chassis, with tyre size 215/70R15 and a rear axle load of 1900kg. Therefore a tyre compression of 30mm is included.

Fiat Ducato X250 with ALKO chassis

Technical specifications

Air-suspension system

Suspension system containing air-springs. The system has a dual-air-circuit with twin height sensors.

The electronics of the air suspension is tested according to EMC (European directives for electronics) directive 72/245/EEC last amended, 2006/28/EC.

The air-suspension can be controlled by the supplied remote control. There are different options for this: VB-SRC (Standard Remote Control) or a simple control unit. It's even possible to control the system through the electrical system or CAN-bus system of the body builder. For more information, contact VB-Airsuspension.

Weights

The weight change of the vehicle after switching to air-suspension is +20kg

Raise- and lowertimes

The raise and lower times depends on the load of the vehicle. The measured values are measured by a rear axle load of 1900kg.

Raise time lowest position > ride height:	66 sec
Raise time ride height > highest position:	58 sec
Lower time highest position > ride height:	22 sec
Lower time ride height > lowest position:	58 sec

Compressor

Contains an air dryer, thermal circuit breaker and a pressure protection valve.

Operating voltage:	12V
Nominal current:	26A
Starting current:	≤ 120A over t ≤ 100ms
Degree of protection :	IP68
Maximum pressure:	10-13 bar

Air-spring

VB-TS (Tapered Sleeve) with double polyamide cord ply and extra low resistance and hysteresis. This air-spring is specially developed for use with light commercial vehicles.

Options

- Emergency valve kit 2C
- Rear-door switch kit
- Extra-time module
- VB-AOWS (Axle Overloading Warning System)

Notes

For the fitting of the air-suspension kit the factory option 081 is required.

This air-suspension kit suits on a Supertiefrahmen chassis of ALKO. For the fitting a special rear axle will be applied.

With the fitting of the air-suspension, the track width of the rear axle will be increased by 30mm.

By fitting the air-suspension kit, the maximum GVW or the maximum axle load is not altered.

This air-suspension kit is also available with full air-suspension for the front-axle. For more information, please contact VB-Airsuspension.

The measured weights are approximately determined.